

## COILMASTER 35 - 45

## Gas Conversion Procedure



- Conversion of the appliance from one gas type to another can only be performed by a qualified professional.
- Gas conversion shall be performed according to applicable local regulations. It is prohibited in some countries. Perform conversion according to the gas category specified for your country on the appliance data plate.
- If the boiler is intended to be used with liquefied gas (propane), installing the boiler below ground level can be hazardous and prohibited in some countries. Please refer to applicable local regulations for installation requirements.
- If the boiler is already installed before conversion, the boiler must be turned off, the power supply must be disconnected through the external fuse or circuit breaker, and the gas supply to the gas valve must be closed.



- Make sure that the gas type and pressure of the distribution network are compatible with the appliance, as per the information on the appliance data plate.
- If the boiler was running before conversion, allow it to cool down before performing any task.



*After gas conversion is performed, control the gas pressure and consumption at appliance start up, and perform the adjustment procedures provided in “Adjustment of Fan Speeds” on page 3 and “Combustion Adjustment” on page 4.*

### Summary

This procedure consists in replacing the factory-installed air-gas mixer for G20 natural gas attached to the fan, by an air-gas mixer for either G25 natural gas or G31 liquefied gas (Propane). See **Fig. 1** opposite for air-gas mixer location.

See table below for air-gas mixer top and bottom injector sizes:

Models	G25	G31
	Top - Bottom	Top - Bottom
CM 35 / 45	4.3 - 5.4	3.3 - 3.4

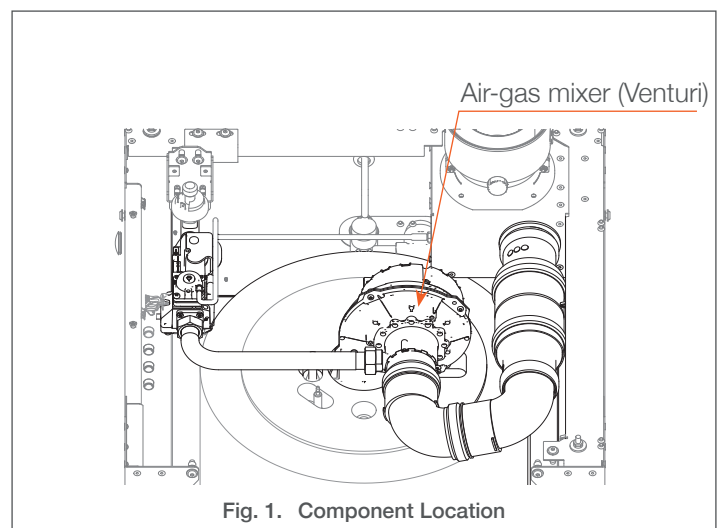

Fig. 1. Component Location

# COILMASTER 35 - 45 - GAS CONVERSION PROCEDURE

## Air-Gas Mixer Replacement

### Conditions:

- › Boiler turned off using the appliance on/off switch
- › Power supply deactivated through external electrical box (fuse or circuit breaker)
- › Gas supply shut down
- › Boiler cooled down
- › Front and top panel removed. Please refer to the Installation and Maintenance Manual for the correct procedure.

### Tools and material:

- › Wrench, hex head
- › Screwdriver, flat
- › Torque wrench
- › Protective gloves

### Air-Gas Mixer Removal Procedure (Fig. 2)

1. Disconnect gas supply from boiler gas connection.
2. Disconnect all connectors and ground wires from the electrodes and the fan.
3. Wearing protective gloves, remove rock wool insulation from the upper plate. Retain for reinstallation.
4. Disconnect the air inlet duct (1) from the air-gas mixer (6) and the flue box (8).
5. Release gas tube union (2) from gas valve (3). Check the gasket (5) condition and replace as required.
6. Release union (4) securing the gas tube to the air-gas mixer (6). Check the gasket (5) condition and replace as required.

7. Release 3 screws and washers securing the air-gas mixer (6) to the fan (7).
8. Remove the air-gas mixer (6) and O-ring, as well as hardware. Retain hardware for reinstallation.



*When removing the air-gas mixer, check the general condition of the O-ring. Discard and replace the O-ring if it is cracked or torn.*

### Air-Gas Mixer Installation Procedure (Fig. 2)

1. Install the new air-gas mixer (6) on fan (7) using hardware retained at removal and O-ring.
2. Install gasket (5) and fasten the gas tube to the air-gas mixer (6) with union (4).
3. Install gasket (5) and fasten the gas tube to the gas valve (3) with union (2).
4. Connect the air inlet duct (1) to the air-gas mixer (6) and flue box (8).
5. Wearing protective gloves, install insulation on the burner door.
6. Reconnect all connectors and grounding wires to the electrodes and fan (7).
7. Connect gas supply to boiler gas connection.

### Follow-on Task(s)

- › Open gas supply to the boiler.
- › Check the absence of leaks.
- › Perform the fan speed adjustment. See **“Adjustment of Fan Speeds” on page 3.**

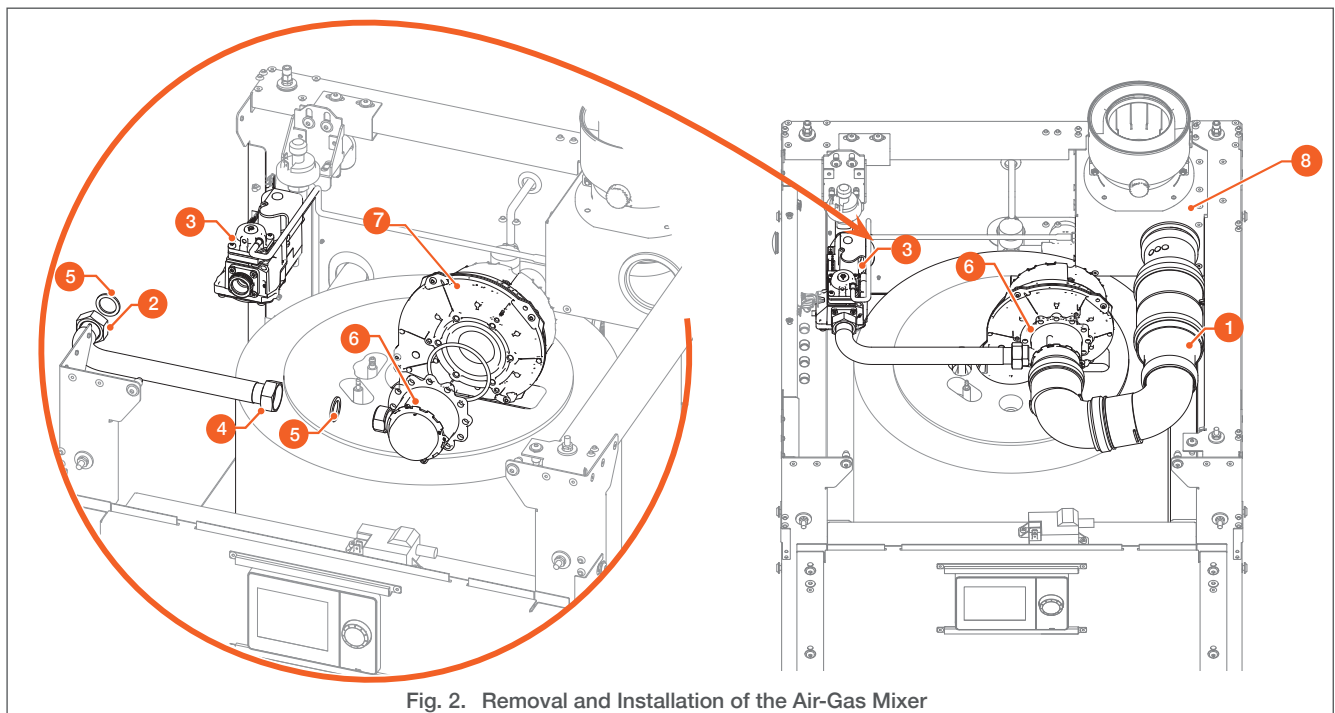



Fig. 2. Removal and Installation of the Air-Gas Mixer

## Adjustment of Fan Speeds

### Conditions:

- › Boiler full of water and under pressure
- › Gas supply open
- › Power supply activated through external electrical box (fuse or circuit breaker)

### Adjustment Procedure (Fig. 3)

1. Restart the boiler according to the procedure provided in the installation manual of the appliance.
2. Rotating the selector (1) and depressing it to confirm each selection:
  - › select the  icon,
  - › select “Expert”,
  - › in “Select user level”; select “Engineer”, then “Continue”
  - › select the  icon,
  - › select “complete parameter list”,
  - › select “Time of day and date” to access the list of menus.
3. Rotating the selector (1), scroll to the bottom of the list, “Burner Control”,
4. On page “(4/12)”, select “9524 Required speed LF”. Press the selector (1) to modify the value. The value is displayed in white on a black background (2).
5. Rotating the selector (1), adjust the minimum fan speed according to the table shown at the bottom of the page.
6. Press the selector (1) to confirm and save the value.
7. Rotating the selector, go up the screen, back to the Burner Control page number. Select page number “(4/12)” by pressing the selector (1), then go to the following page.
8. On page “(5/12)”, select “9529 Required speed HF”. Press the selector (1) to modify the value. The value is displayed in white on a black background.
9. Rotating the selector (1), adjust the nominal fan speed according to the table shown at the bottom of the page.
10. Press the selector (1) to confirm and save the value.
11. Press the selector (1) for more than 3 sec. to exit the setting menu.

### Follow-on Task(s)

- › Perform the combustion adjustment. See “Combustion Adjustment” on page 4.

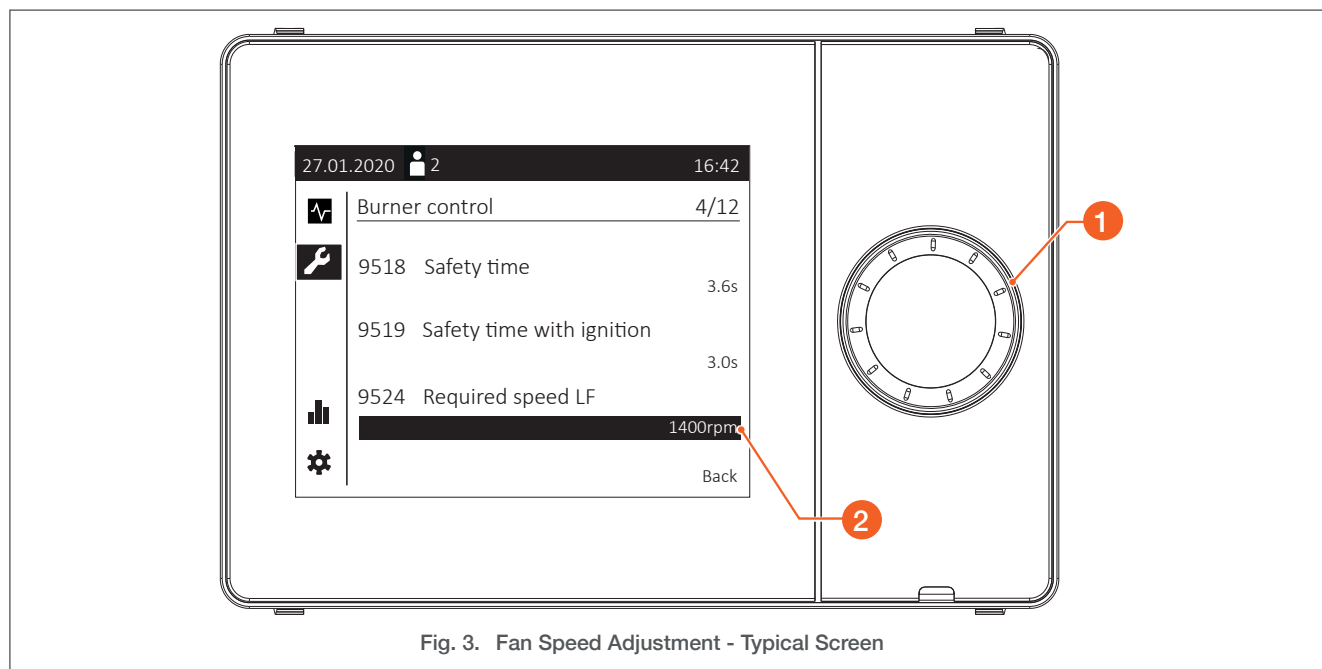

Fig. 3. Fan Speed Adjustment - Typical Screen

			CM 35	CM 45
Fan speeds for G25 (Natural Gas)	Minimum	rpm	1,500	1,500
	Nominal	rpm	5,200	6,500
Fan speeds for G31 (Propane Gas)	Minimum	rpm	1,400	4,800
	Nominal	rpm	1,400	6,000

# COILMASTER 35 -45 - GAS CONVERSION PROCEDURE

## Combustion Adjustment

### Conditions:

- › Boiler full of water and under pressure
- › Gas supply open
- › Power supply activated through external electrical box (fuse or circuit breaker)
- › Boiler turned on using the On/Off switch

### Tools and material:

- › Flue gas analyser
- › Screwdriver, flat head, size 3
- › Wrench, hex head, sizes 2 and 2.5

### Adjustment Procedure (Figs. 4 & 5):

1. Activate the required heating mode.
2. Allow the boiler to operate for a few minutes.
3. Connect the flue gas analyser probe to the measuring port of the flue gas pipe.
4. Check CO<sub>2</sub> contents in the flue gas at max output as follows:
  - › Using the rotary selector (1), select and activate the  icon,
  - › Select “Special operations (1/3)”,
  - › Set “Chimney sweep function” to “On”,
  - › Set “Burner output” to “Full load”.

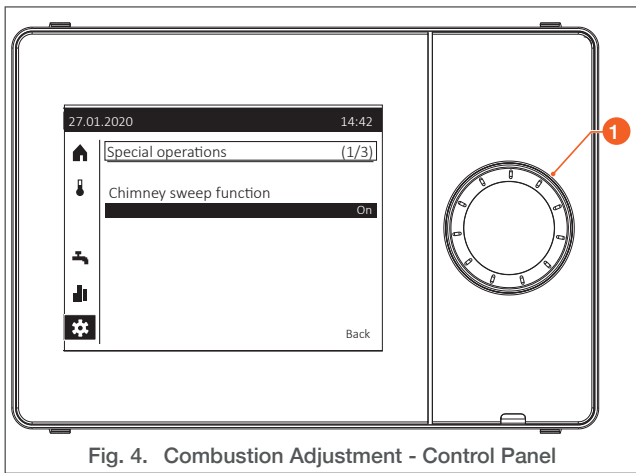

Fig. 4. Combustion Adjustment - Control Panel

5. Check the CO<sub>2</sub> (or O<sub>2</sub>) contents displayed on the gas analyser, and compare the values with those in the table below.

		@Min output	@Max output
G25	%CO <sub>2</sub>	8.4 (±0.1)	8.8 (±0.1)
G31	%CO <sub>2</sub>	10.0 (+0.2)	10.5 (+0.2)
G25	%O <sub>2</sub>	5.7 (±0.18)	4.9 (±0.18)
G31	%O <sub>2</sub>	5.7 (-0.30)	4.9 (-0.30)

6. If the value is outside the range, adjust the combustion value by turning the gas valve throttle (2) in small steps. Allow the value to stabilise before performing additional adjustments.
  - Rotate throttle screw **clockwise (to the right) to decrease** the CO<sub>2</sub> contents.
  - Rotate throttle screw **counter-clockwise (to the left) to increase** the CO<sub>2</sub> contents.
7. Check CO<sub>2</sub> contents in the flue gas at min. output as follows:
  - › Set “Burner output” to “Partial load”.
  - › Check the CO<sub>2</sub> contents, and compare the values with those in the table at the bottom of the page.
  - › If the value is outside the range, adjust the combustion value by turning the offset screw (3) in small steps. Allow the value to stabilise before performing additional adjustments.



*The offset screw (3) is factory-sealed. After adjustment, make sure to reseal it.*

8. In “Special operations (1/3)”, set “Chimney sweep function” to “off”.
9. Press the selector (1) for more than 3 sec. to exit the setting menu.
10. Restart the boiler to check the ignition behaviour. Control the correct operation of the boiler by repeating steps 1 to 7.
11. Reseal the offset screw (3) using some paint or tape.

### Follow-on Task(s):

- › On the gas valve (Fig. 5), place the yellow sticker indicating that a gas conversion has been carried out.
- › On the data plate (back of the boiler), place the white sticker indicating that a gas conversion has been carried out.
- › Reinstall front and top panels, Please refer to the appliance Installation and Maintenance manual for the correct procedure.
- › Record the combustion values in the log sheet available in the installation manual of the appliance.

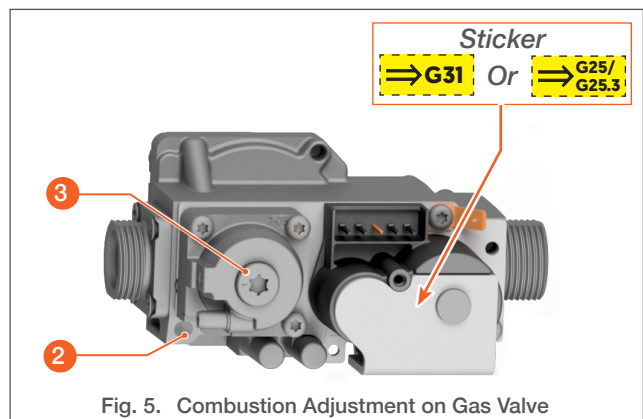

Fig. 5. Combustion Adjustment on Gas Valve